

## MICROLITHIC™ DOUBLE-BALANCED MIXER

## ML1-0110SM

The ML1-0110SM is a Surface Mount Microlithic™ double balanced mixer. As with all Microlithic™ mixers, it features excellent conversion loss, isolation, and spurious performance across a broad bandwidth and in a miniaturized form factor. Accurate, nonlinear software models are available for Microwave Office through the Marki Microwave PDK. The ML1-0110SM is a lead free, RoHS compliant package compatible with standard leaded and lead-free solder reflows. SMA connectorized evaluation packages are available. The ML1-0110SM is an excellent alternative to Marki Microwave M1 and M3 mixers packaged in surface mount packages such as the EZ package.



MICROLITHIC

### Features

- Compact SMT Style Package (0.152" x 0.090" x 0.045")
- CAD Optimized for Superior Isolation and Spurious Response
- Broadband Performance
- Excellent Unit-to-Unit Repeatability
- Fully nonlinear software models available with Marki PDK for Microwave Office
- RoHS Compliant

Mixer Line	Suitable Alternative for Models
M1	M1-0204, M1-0208, M1-0212, M1-0310, M1-0408, M1-0412
M3	M3-0309, M3-0312, M3-0408, M3-0412

### Electrical Specifications - Specifications guaranteed from -55 to +100°C, measured in a 50Ω system.

Parameter	LO (GHz)	RF (GHz)	IF (GHz)	Min	Typ	Max	Diode Option <sup>1</sup> LO drive level (dBm)
Conversion Loss (dB)	1.5-10		DC-1		7	10	
			1-2		9	11	
Isolation (dB)					See Plots		
LO-RF							
LO-IF							
RF-IF							
Input 1 dB Compression (dBm)					+3		L (+8 to +13)
					+9		H (+16 to +20)
Input Two-Tone Third Order Intercept Point (dBm)					+12		L (+8 to +13)
					+21		H (+16 to +20)

<sup>1</sup>Contact factory for other diode options.

### Part Number Options

Model Number	Description
ML1-0110LSM-2, ML1-0110LSM-1 <sup>1</sup>	Surface Mount, L-Diode, I Port Configuration -2 or Configuration -1
ML1-0110HSM-2, ML1-0110HSM-1 <sup>1</sup>	Surface Mount, H-Diode, I Port Configuration -2 or Configuration -1
EVAL-ML1-0110L	Connectorized Evaluation Fixture, L-Diode
EVAL-ML1-0110H	Connectorized Evaluation Fixture, H-Diode

<sup>1</sup>See -2 and -1 configuration options on page 4.

215 Vineyard Court, Morgan Hill, CA 95037 | Ph: 408.778.4200 | Fax 408.778.4300 | info@markimicrowave.com

# MICROLITHIC™ DOUBLE-BALANCED MIXER

# ML1-0110SM

Page 2

LO/RF 1.5 to 10 GHz  
IF DC to 2 GHz

Typical Performance

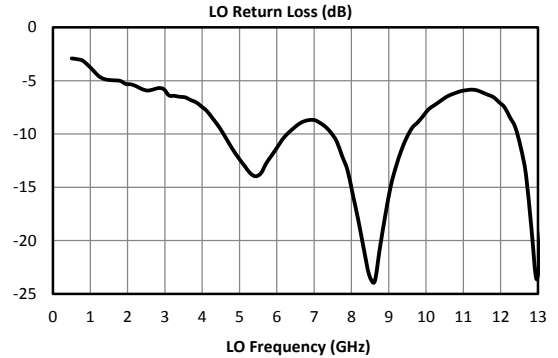
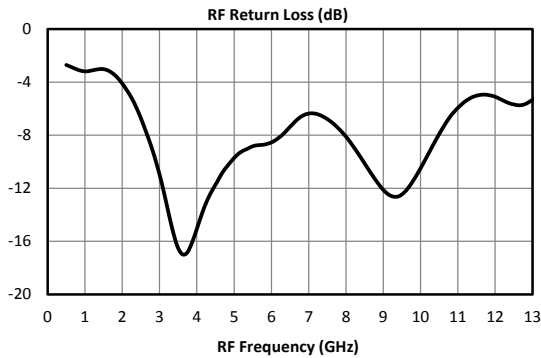
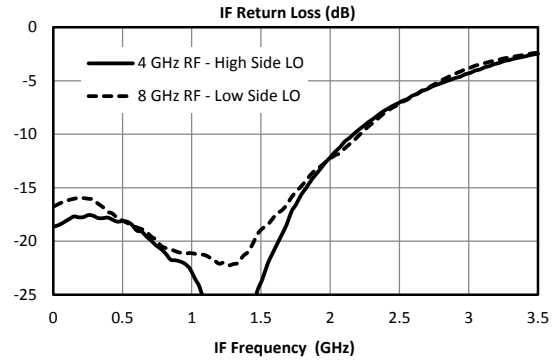
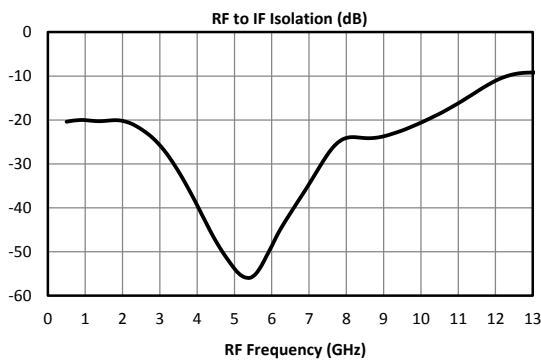
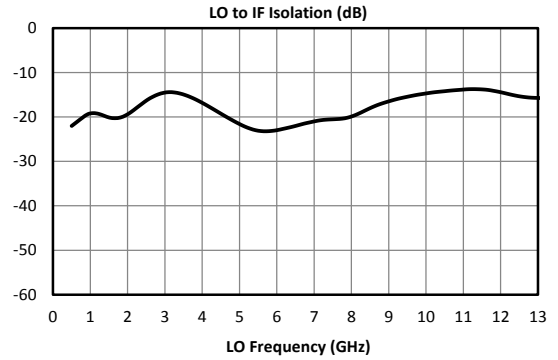
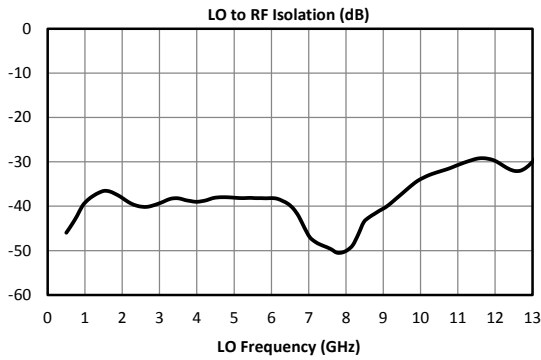
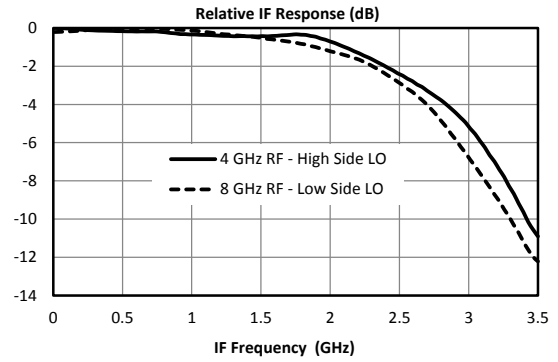
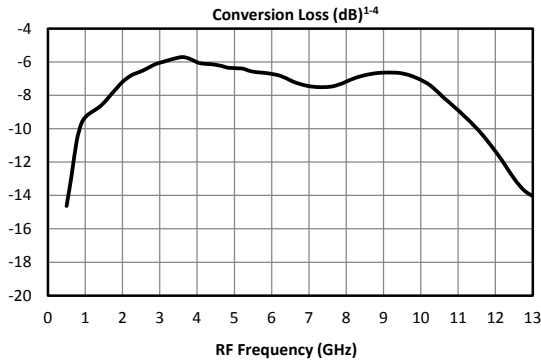

# MICROLITHIC™ DOUBLE-BALANCED MIXER

# ML1-0110SM

Page 3

LO/RF 1.5 to 10 GHz  
IF DC to 2 GHz

## Typical Performance

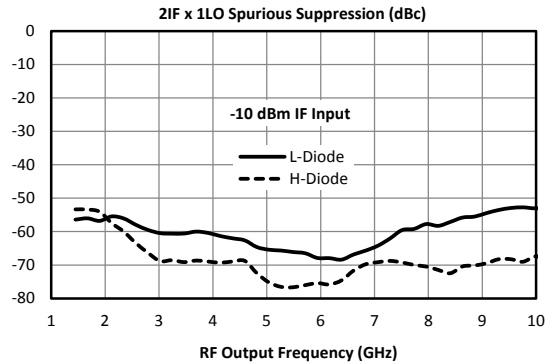
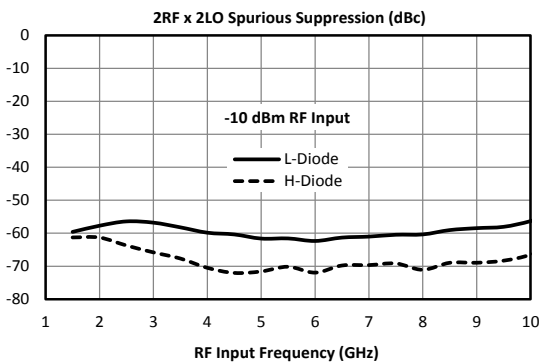
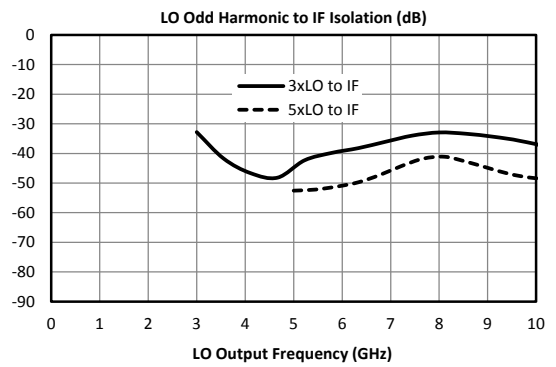
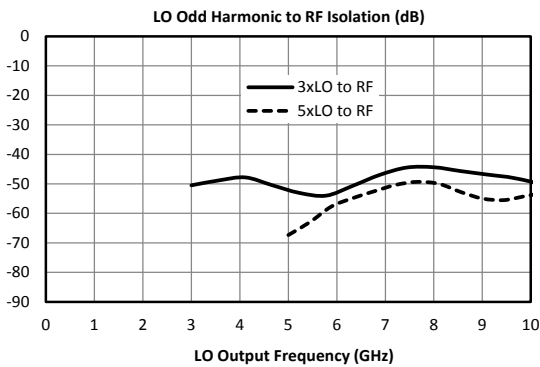
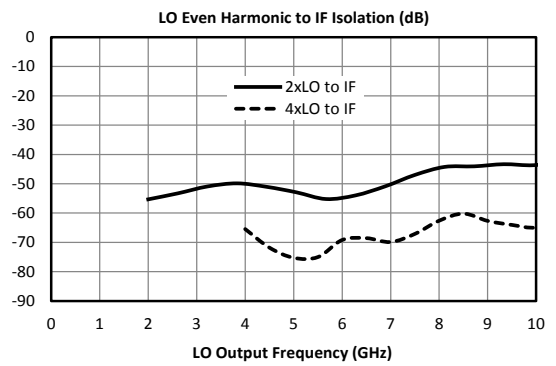
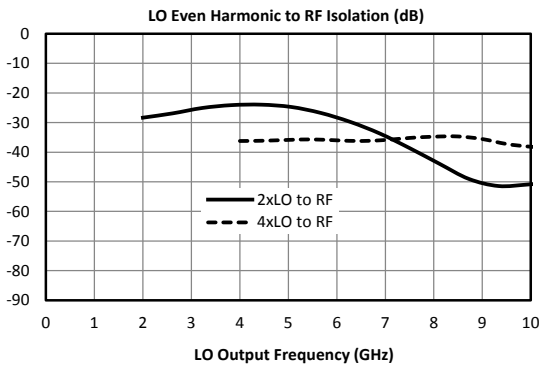
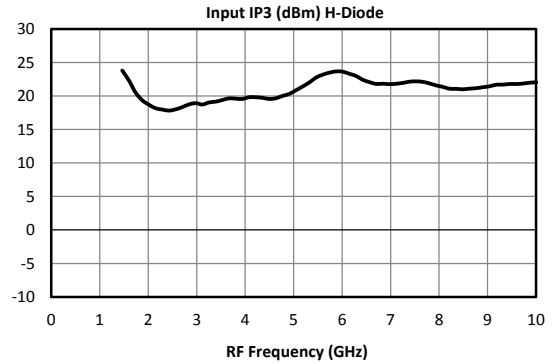
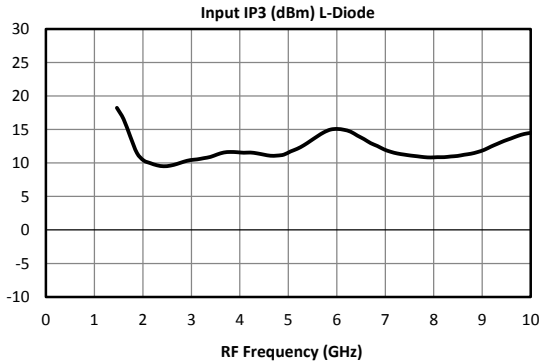

**MICROLITHIC™ DOUBLE-BALANCED MIXER**

**ML1-0110SM**

Page 4

LO/RF 1.5 to 10 GHz  
IF DC to 2 GHz

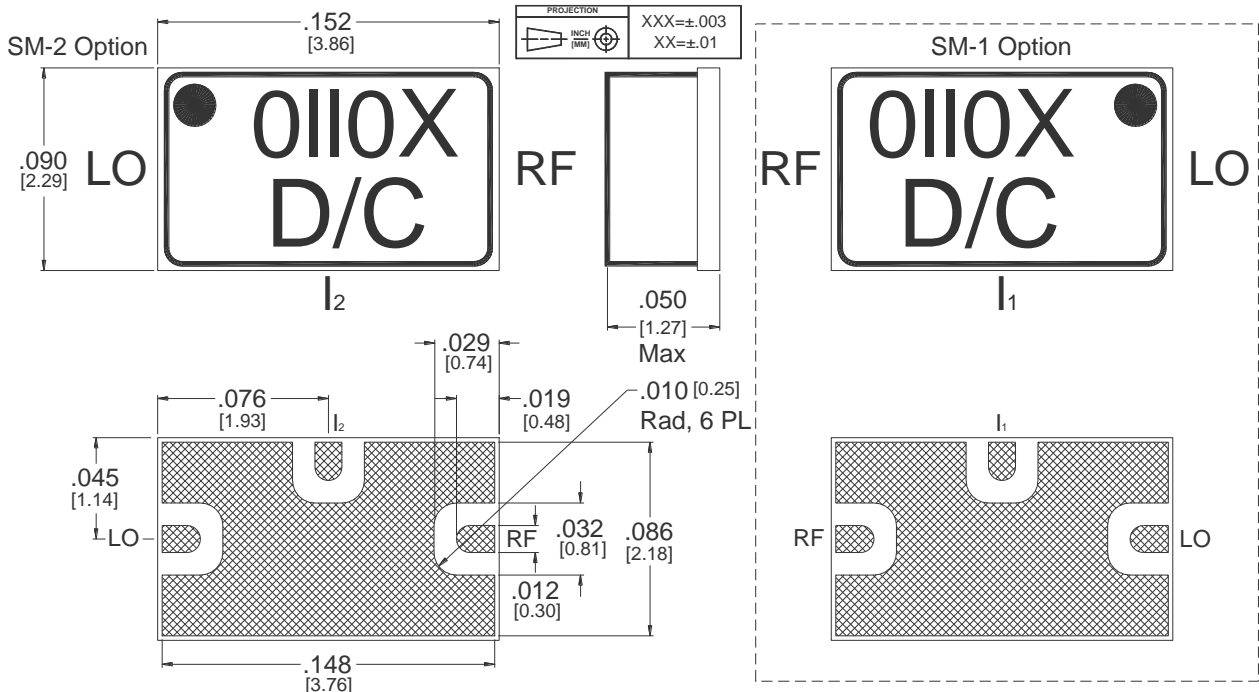

Outline Drawing – SM-2 and SM-1 Packages

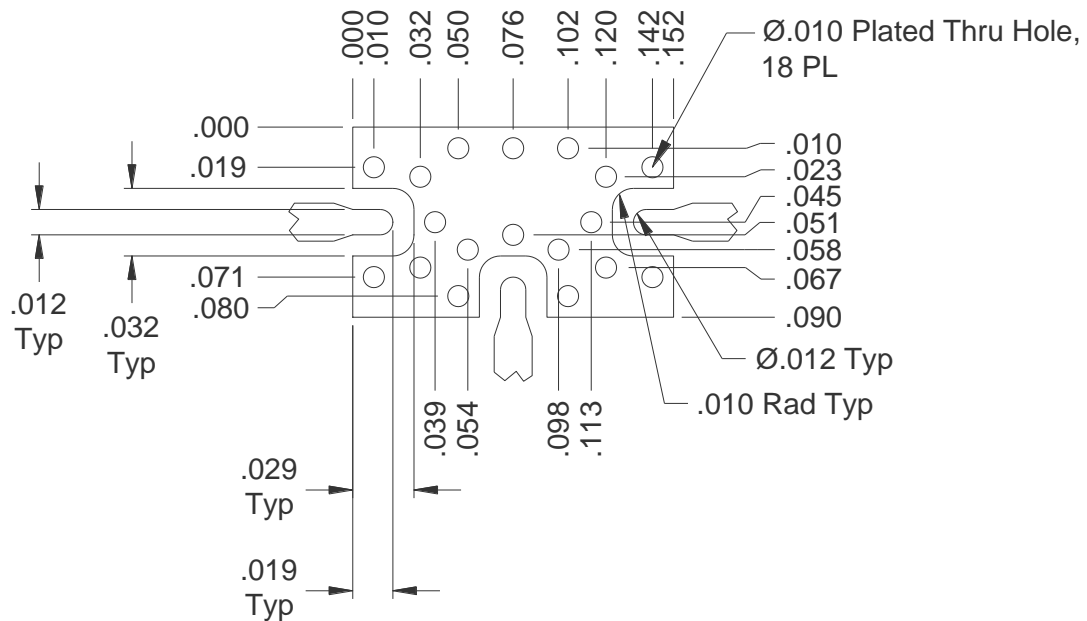

SM-Package Surface-Mount System Circuit Footprint

[Click here for a DXF of the above layout.](#)

[Click here for leaded solder reflow.](#) [Click here for lead-free solder reflow.](#)



# MICROLITHIC™ DOUBLE-BALANCED MIXER

# ML1-0110SM

Page 5

LO/RF 1.5 to 10 GHz  
IF DC to 2 GHz

### Downconversion Spurious Suppression

Spurious data is taken by selecting RF and LO frequencies ( $\pm mLO \pm nRF$ ) within the RF/LO bands, to create a spurious output within the IF band. The mixer is swept across the full spurious band and the mean is calculated. The numbers shown in the table below are for a -10 dBm RF input. Spurious suppression is scaled for different RF power levels by  $(n-1)$ , where “n” is the RF spur order. For example, the  $2RFx2LO$  spur is 68 dBc for the H-diode version for a -10 dBm input, so a -20 dBm RF input creates a spur that is  $(2-1) \times (-10 \text{ dB})$  dB lower, or 78 dBc.

**Typical Downconversion Spurious Suppression (dBc): H-diode (L-diode) <sup>5</sup>**

-10 dBm RF Input	0xLO	1xLO	2xLO	3xLO	4xLO	5xLO
1xRF	18 (18)	Reference	29 (31)	12 (11)	30 (31)	25 (23)
2xRF	68 (63)	55 (49)	68 (59)	56 (48)	65 (59)	54 (51)
3xRF	90 (75)	66 (50)	79 (65)	72 (56)	80 (64)	70 (54)
4xRF	96 (87)	112 (86)	109 (88)	107 (83)	111 (93)	106 (85)
5xRF	112 (96)	119 (91)	126 (99)	119 (84)	129 (102)	122 (93)

### Upconversion Spurious Suppression

Spurious data is taken by mixing an input within the IF band, with LO frequencies ( $\pm mLO \pm nIF$ ), to create a spurious output within the RF output band. The mixer is swept across the full spurious output band and the mean is calculated. The numbers shown in the table below are for a -10 dBm IF input. Spurious suppression is scaled for different IF input power levels by  $(n-1)$ , where “n” is the IF spur order. For example, the  $2IFx1LO$  spur is typically 68 dBc for the H-diode version for a -10 dBm input, so a -20 dBm IF input creates a spur that is  $(2-1) \times (-10 \text{ dB})$  dB lower, or 78 dBc.

**Typical Upconversion Spurious Suppression (dBc): H-diode (L-diode) <sup>5</sup>**

-10 dBm IF Input	0xLO	1xLO	2xLO	3xLO	4xLO	5xLO
1xIF	13 (14)	Reference	29 (30)	11 (11)	29 (32)	20 (20)
2xIF	57 (51)	68 (61)	55 (50)	58 (53)	42 (38)	58 (54)
3xIF	89 (75)	74 (61)	81 (69)	65 (53)	71 (60)	62 (50)
4xIF	117 (98)	113 (94)	106 (90)	101 (92)	88 (77)	95 (88)
5xIF	132 (115)	118 (93)	124 (108)	110 (91)	116 (100)	102 (92)



# MICROLITHIC™ DOUBLE-BALANCED MIXER

## ML1-0110SM

Page 6

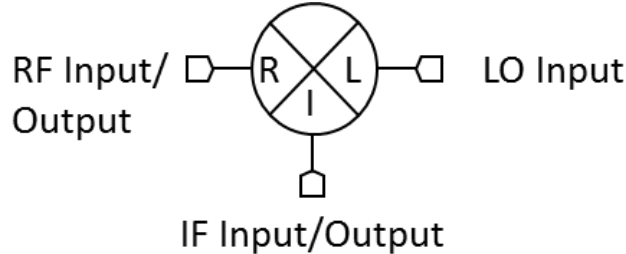
LO/RF 1.5 to 10 GHz  
IF DC to 2 GHz

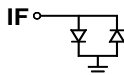

Port	Description	DC Interface Schematic
LO	The LO port is DC short to ground and AC matched to 50 Ohms from 1.5 to 10 GHz. Blocking capacitor is optional.	
RF	The RF port is DC short to ground and AC matched to 50 Ohms from 1.5 to 10 GHz. Blocking capacitor is optional.	
IF	The IF port is DC coupled to the diodes. Blocking capacitor is optional.	

Absolute Maximum Ratings	
Parameter	Maximum Rating
RF DC Current	1 Amp
LO DC Current	1 Amp
IF DC Current	50 mA
RF Power Handling (RF+LO)	+25 dBm at +25°C, derated linearly to +20 dBm at +100°C
Operating Temperature	-55°C to +100°C
Storage Temperature	-65°C to +125°C

### DATA SHEET NOTES:

- Mixer Conversion Loss Plot IF frequency is 100 MHz.
- Mixer Noise Figure typically measures within 0.5 dB of conversion loss for IF frequencies greater than 5 MHz.
- Conversion Loss typically degrades less than 0.5 dB for LO drives 2 dB below the lowest and 3 dB above highest nominal LO drive levels.
- Conversion Loss typically degrades less than 0.5 dB at +100°C and improves less than 0.5 dB at -55°C.
- Unless otherwise specified L diode data taken with +10 dBm LO drive and H diode data is taken with +17 dBm LO drive.
- Specifications are subject to change without notice. Contact Marki Microwave for the most recent specifications and data sheets.
- Catalog mixer circuits are continually improved. Configuration control requires custom mixer model numbers and specifications.

Marki Microwave reserves the right to make changes to the product(s) or information contained herein without notice. Marki Microwave makes no warranty, representation, or guarantee regarding the suitability of its products for any particular purpose, nor does Marki Microwave assume any liability whatsoever arising out of the use or application of any product.

© Marki Microwave, Inc.



215 Vineyard Court, Morgan Hill, CA 95037 | Ph: 408.778.4200 | Fax 408.778.4300 | [info@markimicrowave.com](mailto:info@markimicrowave.com)  
[www.markimicrowave.com](http://www.markimicrowave.com)