

GaAs MMIC Triple Balanced Mixer

MM2-0530L

Page 1

The MM2-0530L is a passive MMIC triple balanced mixer. It features a broadband IF port that spans from 2 to 20 GHz, and has excellent spurious suppression. GaAs MMIC technology improves upon the previous generation of hand assembled, hybrid M2 triple balanced mixers with improved isolations, unit-to-unit repeatability and reliability. The MM2-0530L is available as a wire bondable chip or connectorized SMA package.

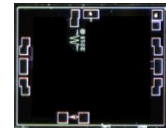
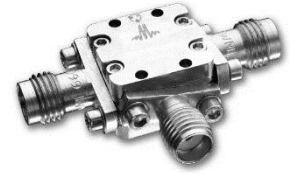

Features

- Broadband IF Port
- Typical Input 1 dB Compression of +8 dBm
- High Input IP3 of +19 dBm
- Excellent LO to IF Isolation
- Unit-to-Unit Repeatability
- RoHS Compliant

Electrical Specifications - Specifications guaranteed from -55 to +100°C, measured in a 50Ω system. Specifications are shown for Configurations A (B). See page 2 for port locations. All bare die are 100% DC tested and 100% visually inspected. RF testing is performed on a sample basis to verify conformance to datasheet guaranteed specifications. Consult factory for more information.

Parameter	LO (GHz)	RF (GHz)	IF (GHz)	Min	Typ	Max	LO drive level (dBm)
Conversion Loss (dB) ¹	5-30	5-30	2-20		9 (10)		+15
Isolation (dB) LO-RF LO-IF RF-IF					See Plots		Config. A: + 9 to + 17 Config. B: + 9 to + 17
Input 1 dB Compression (dBm)					8 10		
Input Two-Tone Third Order Intercept Point (dBm) ²					+ 15 + 19		

¹Measured Conversion Loss measured at 3 GHz fixed IF

²IP3 depends on LO drive conditions, see plots for more details

Part Number Options

<i>Please specify diode level and package style by adding to model number.</i>				
Package Styles		Examples		
Connectorized ^{1, 3}	S	MM2-0530LCH-2, MM2-0530LS		
Chip ^{2, 3} (RoHS)	CH-2	<u>MM2-0530</u> (Model)	<u>L</u> (Diode Option)	<u>S</u> (Package)

¹Connectorized package consists of chip package wire bonded to a substrate, equivalent to an evaluation board.

²Chip package connects to external circuit through wire bondable gold pads.

³Note: For port locations and I/O designations, refer to the drawings on page 2 of this document.

GaAs MMIC Triple Balanced Mixer

MM2-0530L

Page 2

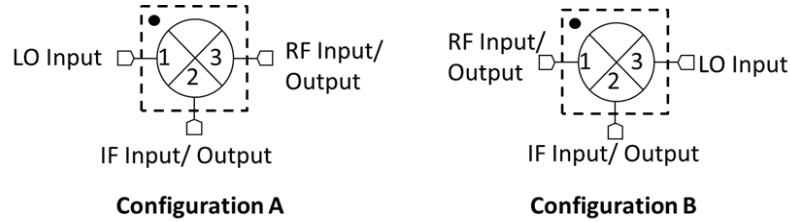

1. Configuration A/B refer to the same part number (MM2-0530L) used in one of two different ways for optimal spurious performance. For the lowest conversion loss, use the mixer in Configuration A (port 1 as the LO input, port 3 as the RF input or output). If you need to use a lower LO drive, use the mixer in Configuration B (port 1 as the RF input or output, port 3 as the LO input). For optimal spurious suppression, experimentation or simulation is required to choose between Configuration A and B. For more information, [see here](#).

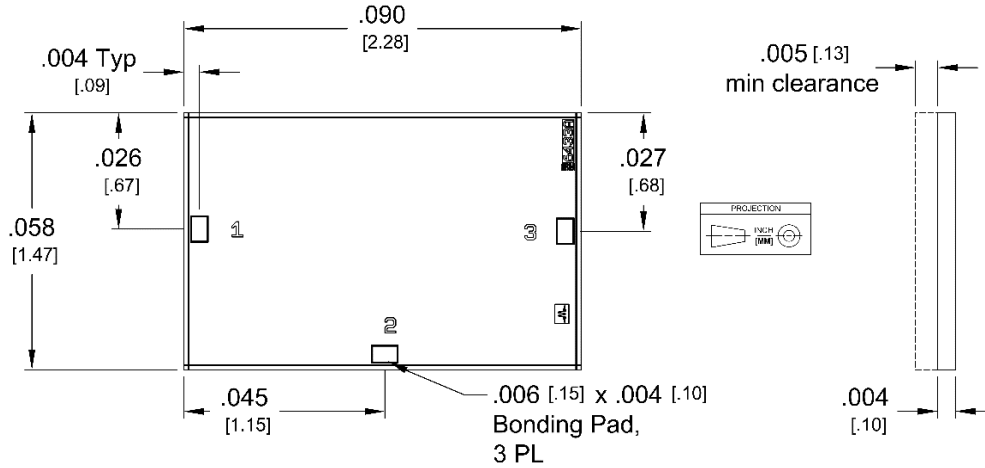

1. CH Substrate material is .004 thick GaAs.
2. I/O traces is 4 microns Au. Ground plane finish is 5 microns Au.
3. Wire Bonding - Ball or wedge bond with 0.025 mm (1 mil) diameter pure gold wire. Thermosonic wirebonding with a nominal stage temperature of 150 °C and a ball bonding force of 40 to 50 grams or wedge bonding force of 18 to 22 grams is recommended. Use the minimum level of ultrasonic energy to achieve reliable wirebonds. Wirebonds should be started on the chip and terminated on the package or substrate. All bonds should be as short as possible <0.31 mm (12 mils).

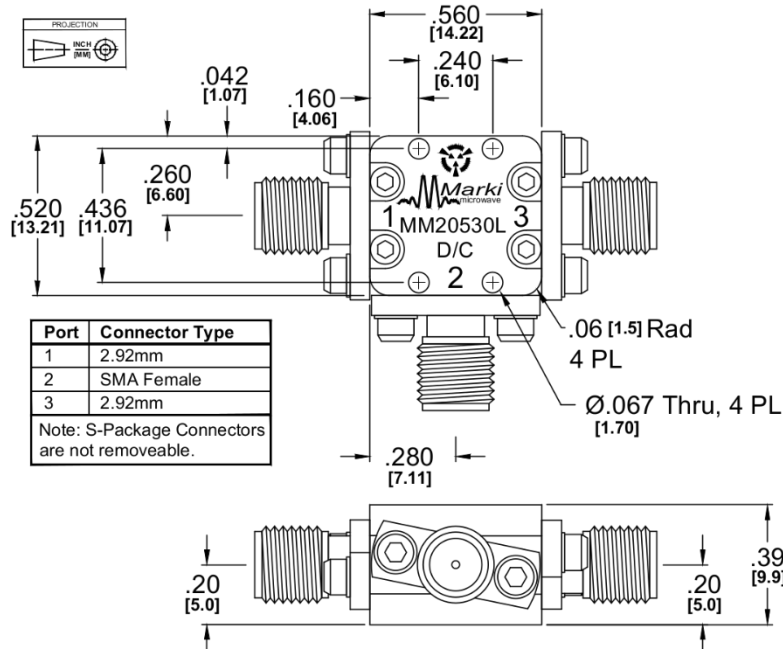

GaAs MMIC Triple Balanced Mixer

MM2-0530L

Page 3

Typical Performance

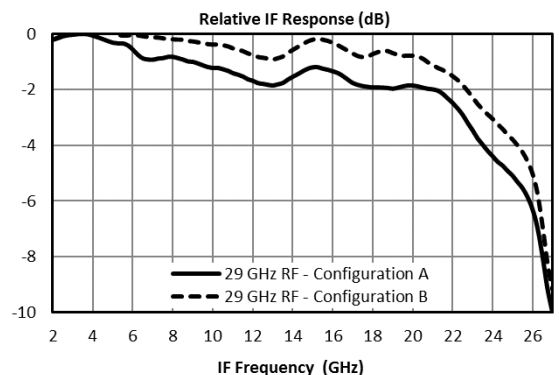
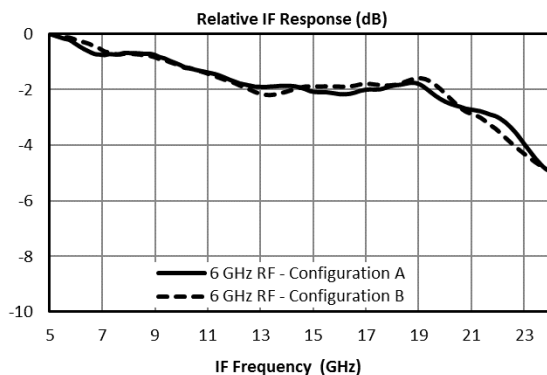
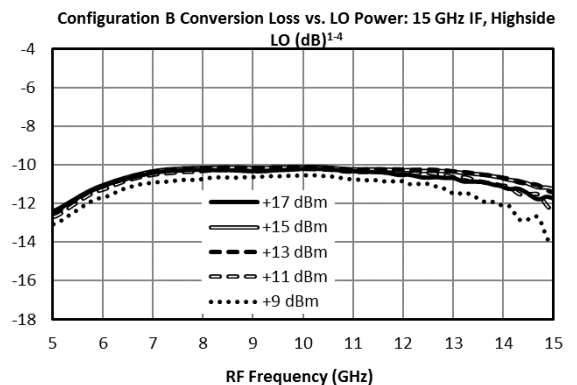
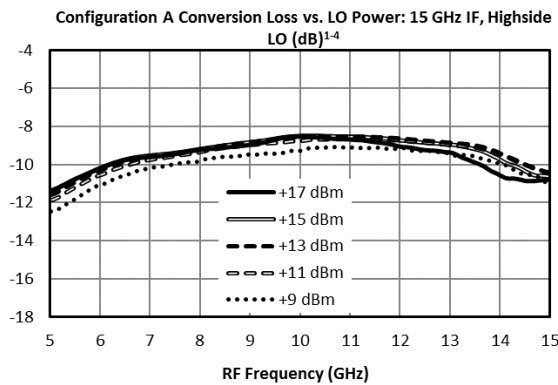
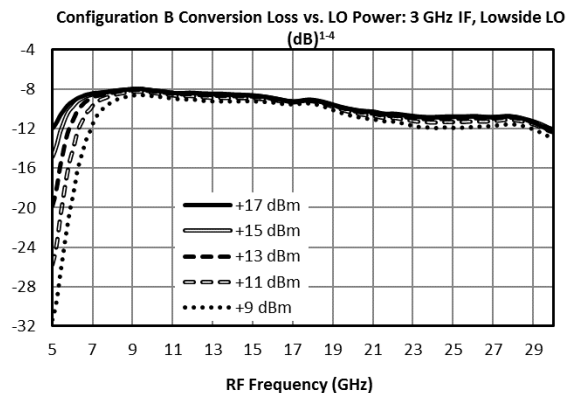
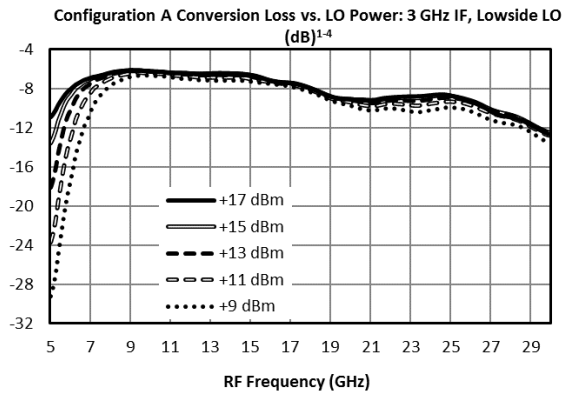
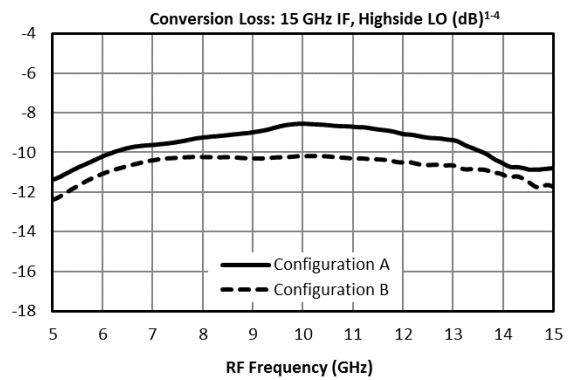
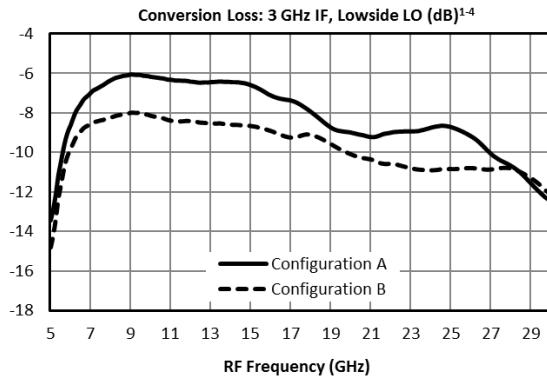

Typical Performance

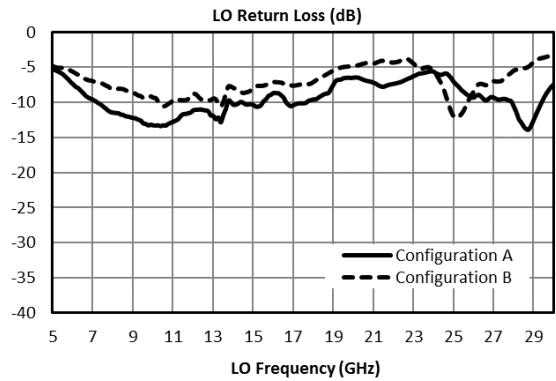
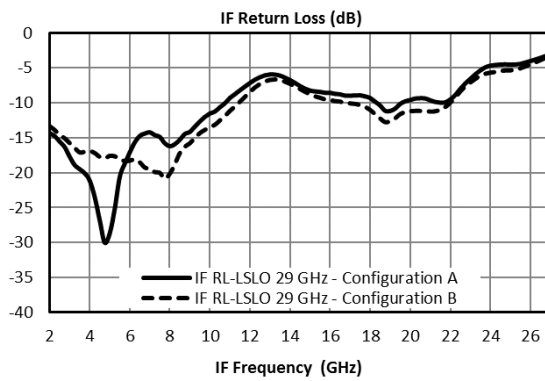
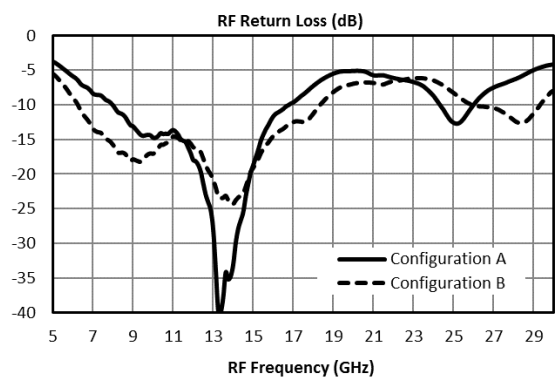
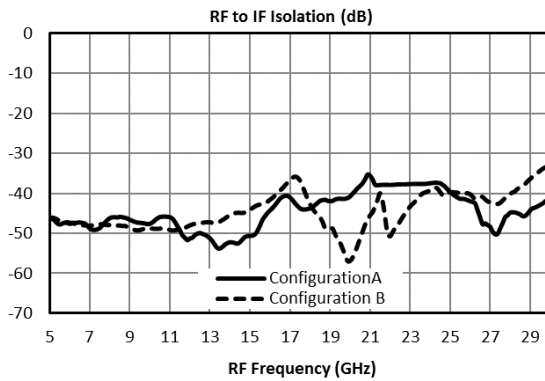
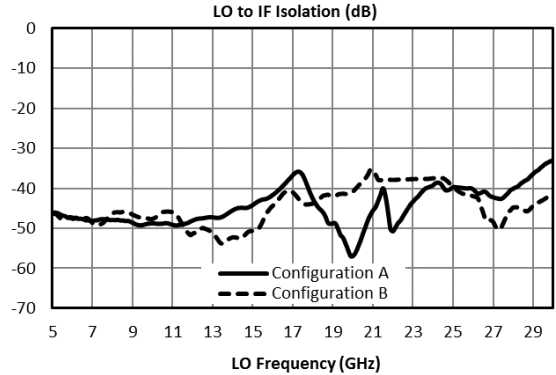
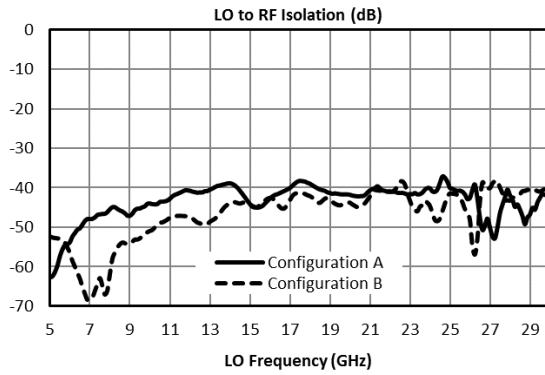

GaAs MMIC Triple Balanced Mixer

MM2-0530L

Page 5

Typical Performance

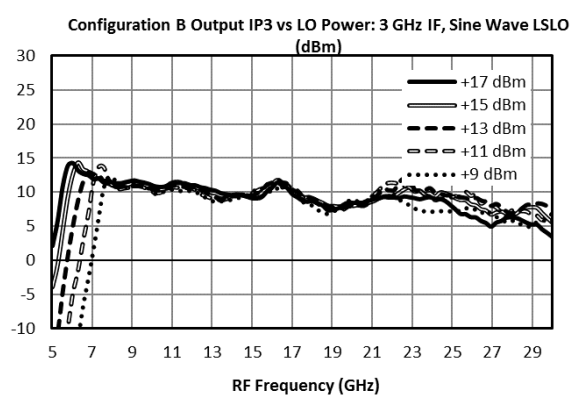
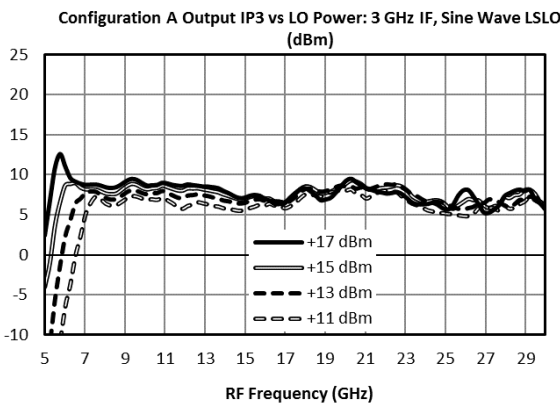
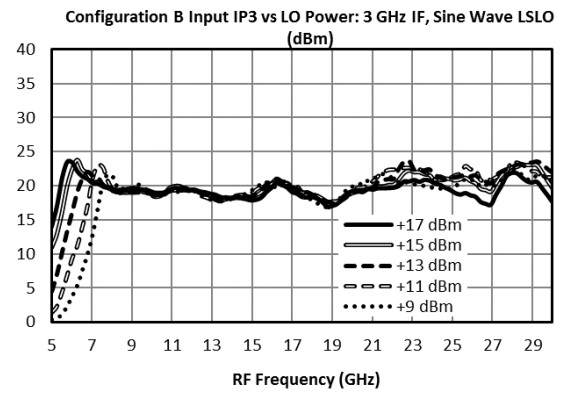
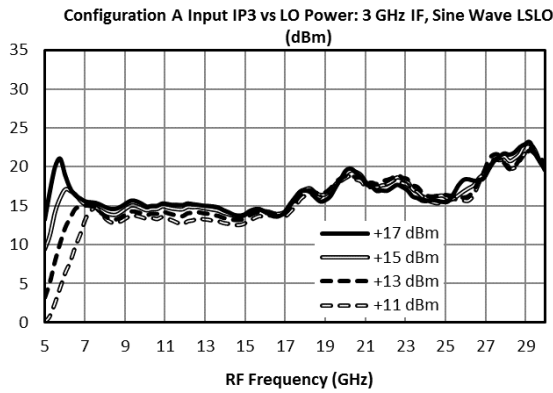
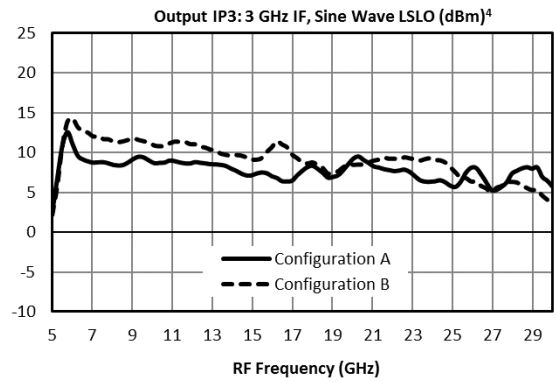
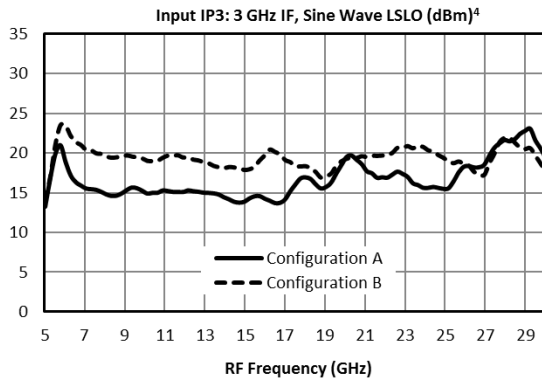

Typical Performance

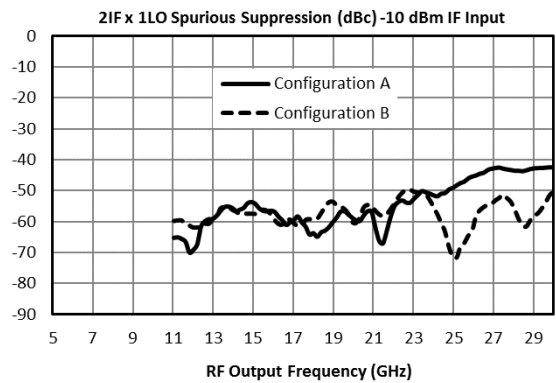
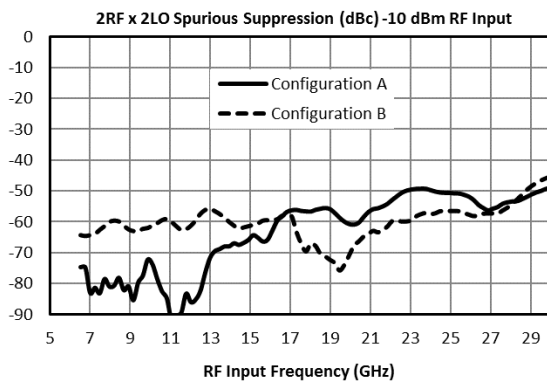
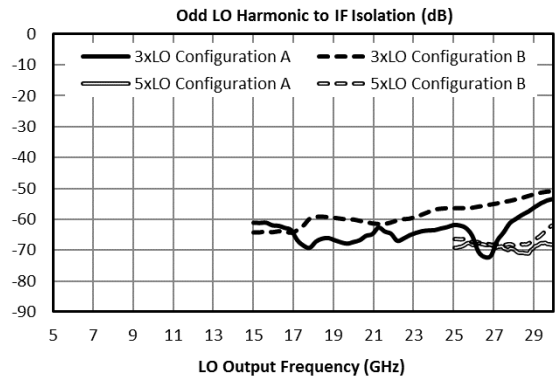
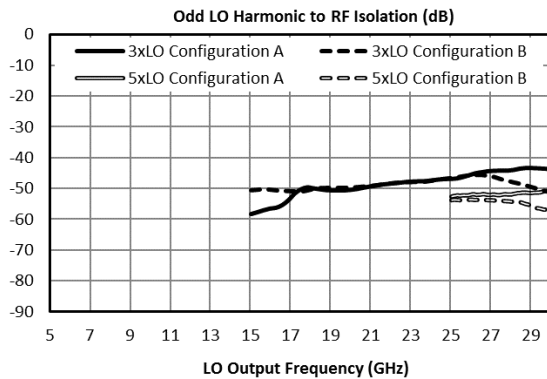
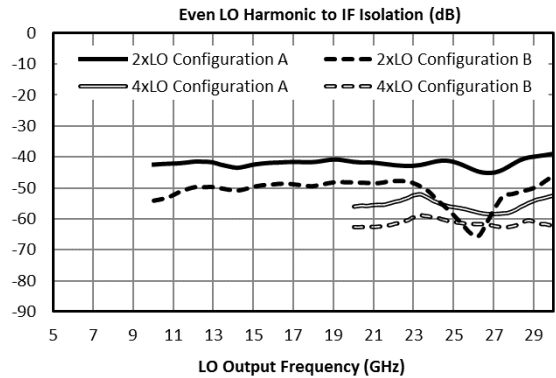
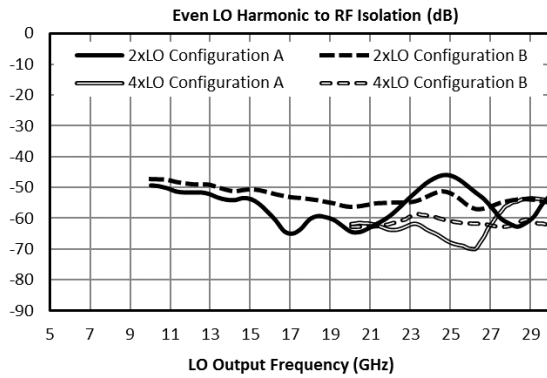



GaAs MMIC Triple Balanced Mixer

MM2-0530L

Page 7

Downconversion Spurious Suppression

Spurious data is taken by selecting RF and LO frequencies ($\pm mLO \pm nRF$) within the 5 to 30 GHz RF/LO bands, which create a 3 GHz IF spurious output. The mixer is swept across the full spurious band and the mean is calculated. The numbers shown in the table below are for a -10 dBm RF input. Spurious suppression is scaled for different RF power levels by (n-1), where “n” is the RF spur order. For example, the 2RFx2LO spur is 59 dBc for the A configuration for a -10 dBm input, so a -20 dBm RF input creates a spur that is (2-1) x (-10 dB) dB lower, or 69 dBc.

Typical Downconversion Spurious Suppression (dBc): A Configuration (B Configuration), Sine Wave LO ⁵

-10 dBm RF Input	0xLO	1xLO	2xLO	3xLO	4xLO	5xLO
1xRF	36 (37)	Reference	36 (44)	14 (12)	38 (43)	29 (21)
2xRF	65 (61)	57 (58)	63 (60)	59 (64)	64 (67)	70 (70)
3xRF	85 (87)	61 (62)	84 (85)	71 (70)	83 (85)	72 (69)
4xRF	152 (153)	82 (110)	113 (114)	116 (117)	115 (110)	116 (119)
5xRF	177 (173)	123 (122)	140 (139)	122 (123)	139 (140)	132 (129)

Upconversion Spurious Suppression

Spurious data is taken by mixing a 3 GHz IF with LO frequencies ($\pm mLO \pm nIF$), which creates an RF within the 5 to 30 GHz RF band. The mixer is swept across the full spurious output band and the mean is calculated. The numbers shown in the table below are for a -10 dBm IF input. Spurious suppression is scaled for different IF input power levels by (n-1), where “n” is the IF spur order. For example, the 2IFx1LO spur is typically 60 dBc for the A configuration for a -10 dBm input, so a -20 dBm IF input creates a spur that is (2-1) x (-10 dB) dB lower, or 70 dBc.

Typical Upconversion Spurious Suppression (dBc): A Configuration (B Configuration), Sine Wave LO ⁵

-10 dBm RF Input	0xLO	1xLO	2xLO	3xLO	4xLO	5xLO
1xIF	38 (40)	Reference	41 (40)	12 (11)	43 (42)	22 (19)
2xIF	71 (66)	54 (58)	60 (62)	67 (66)	70 (66)	68 (63)
3xIF	90 (96)	69 (77)	89 (99)	71 (77)	88 (93)	68 (74)
4xIF	114 (111)	107 (111)	113 (118)	115 (117)	121 (117)	116 (124)
5xIF	134 (140)	125 (127)	138 (139)	119 (123)	141 (141)	123 (121)

GaAs MMIC Triple Balanced Mixer

MM2-0530L

Page 8

Mounting and Bonding Recommendations

Marki MMICs should be attached directly to a ground plane with conductive epoxy. The ground plane electrical impedance should be as low as practically possible. This will prevent resonances and permit the best possible electrical performance. Datasheet performance is only guaranteed in an environment with a low electrical impedance ground.

Mounting - To epoxy the chip, apply a minimum amount of conductive epoxy to the mounting surface so that a thin epoxy fillet is observed around the perimeter of the chip. Cure epoxy according to manufacturer instructions.

Wire Bonding - Ball or wedge bond with 0.025 mm (1 mil) diameter pure gold wire. Thermosonic wirebonding with a nominal stage temperature of 150 °C and a ball bonding force of 40 to 50 grams or wedge bonding force of 18 to 22 grams is recommended. Use the minimum level of ultrasonic energy to achieve reliable wirebonds. Wirebonds should be started on the chip and terminated on the package or substrate. All bonds should be as short as possible <0.31 mm (12 mils).

Circuit Considerations – 50 Ω transmission lines should be used for all high frequency connections in and out of the chip. Wirebonds should be kept as short as possible, with multiple wirebonds recommended for higher frequency connections to reduce parasitic inductance. In circumstances where the chip more than .001” thinner than the substrate, a heat spreading spacer tab is optional to further reduce bondwire length and parasitic inductance.

Handling Precautions

General Handling: Chips should be handled with a vacuum collet when possible, or with sharp tweezers using well trained personnel. The surface of the chip is fragile and should not be contacted if possible.

Static Sensitivity: GaAs MMIC devices are subject to static discharge, and should be handled, assembled, tested, and transported only in static protected environments.

Cleaning and Storage: Do not attempt to clean the chip with a liquid cleaning system or expose the bare chips to liquid. Once the ESD sensitive bags the chips are stored in are opened, chips should be stored in a dry nitrogen atmosphere.

Bonding Diagram

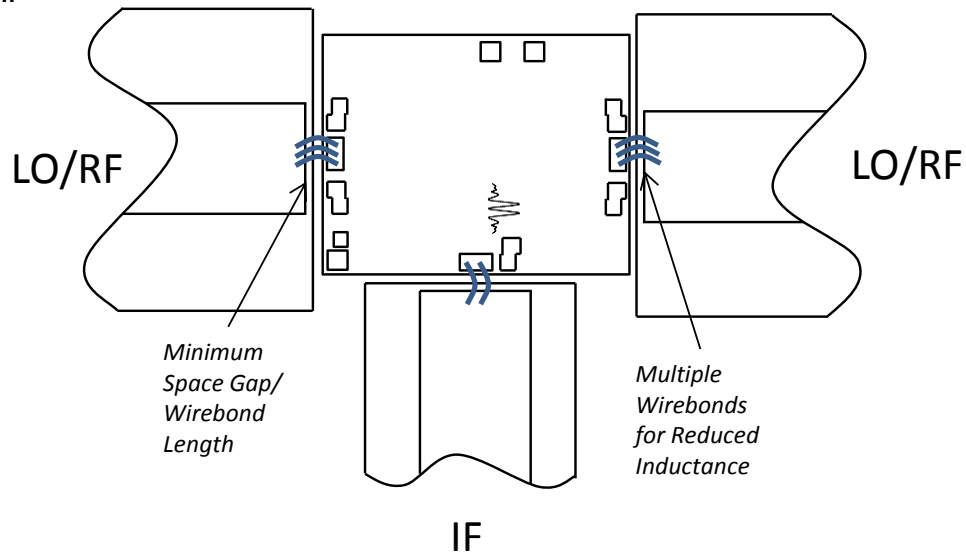

GaAs MMIC Triple Balanced Mixer

MM2-0530L

Page 9

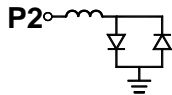
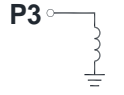
Port	Description	DC Interface Schematic
Port 1	Port 1 is DC short and AC matched to 50 Ω from 5 to 30 GHz. Blocking capacitor is optional.	
Port 2	Port 2 is DC coupled to the diodes. Blocking capacitor is optional.	
Port 3	Port 3 is DC short and AC matched to 50 Ω from 5 to 30 GHz. Blocking capacitor is optional.	

Absolute Maximum Ratings	
Parameter	Maximum Rating
Port 1 DC Current	21 mA
Port 2 DC Current	15 mA
Port 3 DC Current	24 mA
RF Power Handling (RF+LO)	+ 25 dBm at +25°C, derated linearly to +20 dBm at +100°C
Operating Temperature	-55°C to +100°C
Storage Temperature	-65°C to +125°C

DATA SHEET NOTES:

1. Mixer Conversion Loss Plot IF frequency is 3 GHz unless otherwise specified.
2. Mixer Noise Figure typically measures within 0.5 dB of conversion loss for IF frequencies greater than 5 MHz.
3. Conversion Loss typically degrades less than 0.5 dB at +100°C and improves less than 0.5 dB at -55°C.
4. Unless otherwise specified, data is taken with +15 dBm LO drive.
5. Specifications are subject to change without notice. Contact Marki Microwave for the most recent specifications and data sheets.
6. Spurious suppression measurement is not valid; resulting IF is out of band.
7. Catalog mixer circuits are continually improved. Configuration control requires custom mixer model numbers and specifications.

Marki Microwave reserves the right to make changes to the product(s) or information contained herein without notice. Marki Microwave makes no warranty, representation, or guarantee regarding the suitability of its products for any particular purpose, nor does Marki Microwave assume any liability whatsoever arising out of the use or application of any product.

© Marki Microwave, Inc.



215 Vineyard Court, Morgan Hill, CA 95037 | Ph: 408.778.4200 | Fax 408.778.4300 | info@markimicrowave.com
www.markimicrowave.com